

NATIONAL BUILDING CODE OF FINLAND

# Strength and stability of structures

Actions on structures



Ympäristöministeriö  
Miljöministeriet  
Ministry of the Environment

2019

# Foreword

From 1 January 2017 onward, the Ministry of the Environment publishes in the National Building Code of Finland the recommendations for strength and stability related to actions on structures. The instruction contains a compilation of all the National Annexes concerning actions on structures.

Each national annex contains the provisions from the Decree concerning national choices in the application of standard SFS-EN 1991 concerning actions on structures and the recommendations related to the use of the Eurocode. The beginning of the annex presents those clauses in the standard where national choice is permitted, and where such a choice has been made.

Helsinki, 12 December 2019

Building Counsellor

Jukka Bergman

# Contents

## National annexes to Eurocodes SFS-EN 1991

1. National Annex to standard SFS-EN 1991-1-1: Actions on structures. Part 1-1: General actions, densities, self-weight and imposed loads for buildings	4
2. National Annex to standard SFS-EN 1991-1-2: Actions on structures. Part 1-2: General actions. Actions on structures exposed to fire	11
3. National Annex to standard SFS-EN 1991-1-3: Actions on structures. Part 1-3: General actions. Snow loads	14
4. National Annex to standard SFS-EN 1991-1-4: Actions on structures. Part 1-4: General actions. Wind actions	20
5. National Annex to standard SFS-EN 1991-1-5: Actions on structures. Part 1-5: General actions. Thermal actions	26
6. National Annex to standard SFS-EN 1991-1-6: Actions on structures. Part 1-6: General actions. Actions during execution	29
7. National Annex to standard SFS-EN 1991-1-7: Actions on structures. Part 1-7: General actions. Accidental actions	35
8. National Annex to standard SFS-EN 1991-3: Actions on structures. Part 3: Actions induced by cranes and machinery	51
9. National Annex to standard SFS-EN 1991-4: Actions on structures. Part 4: Actions on silos and tanks	54

# National annexes to Eurocodes SFS-EN 1991

## National Annex to standard SFS-EN 1991-1-1: Actions on structures. Part 1-1: General actions, densities, self-weight and imposed loads for buildings

### 1. Scope

**Ministry of the Environment Decree (4/16) concerning national choices for densities, self-weight and imposed loads for buildings, when applying standard SFS-EN 1991-1-1**  
*Section 1 Scope*

This Decree is applied in the selection of densities, self-weight and imposed loads for buildings and is used in conjunction with the latest version of standard SFS-EN 1991-1-1.

#### Instruction

As regards standard SFS-EN 1991-1-1, the recommended values set forth in standard SFS-EN 1991-1-1 and all the annexes to standard SFS-EN 1991-1-1 are followed unless otherwise stated in this National Annex.

National choice is permitted in the following clauses of standard SFS-EN 1991-1-1:

- 2.2(3)
- 5.2.3(1)
- 5.2.3(2)
- 5.2.3(3)
- 5.2.3(4)
- 5.2.3(5)
- 6.3.1.1(1)P (Table 6.1)
- 6.3.1.2(1)P (Table 6.2), Section 3
- 6.3.1.2(10), Section 4
- 6.3.1.2(11), Section 5
- 6.3.2.2(1)P (Table 6.4), Section 6
- 6.3.3.2(1) (Table 6.8), Section 7
- 6.3.4.2(1) (Table 6.10)
- 6.4(1) (Table 6.12), Section 8.

A national choice has been made in the clauses marked •.

## 2. Load arrangements for columns and walls

Ministry of the Environment Decree (4/16) concerning national choices for densities, self-weight and imposed loads for buildings, when applying standard SFS-EN 1991-1-1  
Section 2 Load arrangements for columns and walls

When determining the most unfavourable effect of imposed loads, in accordance with clause 6.2.2(1) of the standard, the imposed load is assumed to be movable at least on the storey just above the column or the wall to be designed.

## 3. Values of actions for designing residential, social, commercial and administration areas

Ministry of the Environment Decree (4/16) concerning national choices for densities, self-weight and imposed loads for buildings, when applying standard SFS-EN 1991-1-1  
Section 3 Values of actions for designing residential, social, commercial and administration areas

The minimum values for imposed loads on floors, balconies and stairs in buildings, clause 6.3.1.2(1)P of the standard, are given in Table 1. The loaded area for concentrated load  $Q_k$  is 50 x 50 mm<sup>2</sup>, if  $Q_k \leq 2.0$  kN; otherwise, the loaded area is 100 x 100 mm<sup>2</sup>.

Table 1. Imposed loads on floors, balconies and stairs in buildings, uniformly distributed load  $q_k$  and concentrated load  $Q_k$

Categories of loaded areas	$q_k$ [kN/m <sup>2</sup> ]			$Q_k$ [kN] (stairs in brackets)
	Intermediate floors	Stairs	Balconies	
<b>Category A</b> Areas for domestic and residential activities	2.0	2.0	2.5	2.0 (2.0*)
<b>Category B</b> Office areas	2.5	3.0	2.5	2.0 (2.0)
<b>Category C</b> Areas where people may congregate	2.5	3.0	2.5	3.0 (2.0)
– C1	3.0	3.0	3.0	3.0 (2.0)
– C2	4.0	3.0	4.0	4.0 (2.0)
– C3	5.0	3.0	5.0	4.0 (2.0)
– C4	6.0	6.0	6.0	4.0 (2.0)
– C5				
<b>Category D</b> Shopping areas				
– D1	4.0	3.0	4.0	4.0 (2.0)
– D2	5.0	6.0	5.0	7.0 (2.0)

\*Stairs in blocks of flats  $Q_k = 1.5$  kN

## 4. Reduction factor

**Ministry of the Environment Decree (4/16) concerning national choices for densities, self-weight and imposed loads for buildings, when applying standard SFS-EN 1991-1-1**  
*Section 4 Reduction factor*

For loaded areas in categories A to D, clause 6.3.1.2(10) of the standard, the value for the reduction factor  $\alpha_A$ , calculated according to equation 6.1, shall be at least 0.8. For loaded areas in other categories, the reduction factor  $\alpha_A$  is 1.0.

A reduction factor  $\alpha_A$  may be applied only to beams and slab structures, in accordance with clause 6.2.1(4) of the standard. The reduction factor may not be applied in structures that are designed as one-way slabs or to horizontal structures with rigid or semi-rigid connection to vertical structures. For continuing horizontal structures the loaded area shall be calculated span by span. Joints between vertical and horizontal structures shall always be designed without a reduction factor.

A reduction factor  $\alpha_A$  shall not be applied in accidental design situations, including fire situations.

For serviceability limit state verifications, a reduction factor  $\alpha_A$  may only be used with a characteristic combination.

The use of a reduction factor  $\alpha_A$  shall be indicated in the design documentation and the party engaging in the building project shall be notified of this.

## 5. Reduction factor for storeys

**Ministry of the Environment Decree (4/16) concerning national choices for densities, self-weight and imposed loads for buildings, when applying standard SFS-EN 1991-1-1**  
*Section 5 Reduction factor for storeys*

A reduction factor  $\alpha_n$  may only be applied to columns and walls and their foundations, in accordance with clause 6.3.1.2(11) of the standard.

The reduction factor  $\alpha_n$  shall not be applied together with a combination factor  $\psi$  or reduction factor  $\alpha_A$ .

## 6. Values of actions on areas for storage and industrial activities

**Ministry of the Environment Decree (4/16) concerning national choices for densities, self-weight and imposed loads for buildings, when applying standard SFS-EN 1991-1-1**

*Section 6 Values of actions on areas for storage and industrial activities*

For loaded storage, production and access areas under category E1, in clause 6.3.2.2(1)P of the standard, the value for imposed loads on intermediate floors  $7.5 \text{ kN/m}^2$  and  $3.0 \text{ kN/m}^2$  for stairs shall be used. The value to be used for concentrated load  $Q_k$  on floors is  $7 \text{ kN}$ , and for stairs, it is  $2.0 \text{ kN}$ .

The reduction factors  $\alpha_A$  and  $\alpha_n$  are not applied to imposed loads on storage and production areas under categories E1 and E2.

The allowable maximum load shall be shown by a permanent sign that is appropriately located and clearly visible. The load shall be stated on this sign in  $\text{kg/m}^2$ .

## 7. Values of actions on garages and vehicle traffic areas

Ministry of the Environment Decree (4/16) concerning national choices for densities, self-weight and imposed loads for buildings, when applying standard SFS-EN 1991-1-1

Section 7 Values of actions on garages and vehicle traffic areas

The values to be used for actions on garages and vehicle traffic areas, clause 6.3.3.2(1) of the standard, are given in Table 2.

**Table 2.** Values of actions on garages and vehicle traffic areas

Category of traffic area	$q_k$ [kN/m <sup>2</sup> ]		$Q_k$ [kN]
	Intermediate floors	Stairs	(stairs in brackets)
<b>Category F</b> Gross vehicle weight: $\leq 30$ kN	2.5	3.0	20 (2.0)
<b>Category G</b> $30$ kN < gross vehicle weight $\leq 160$ kN	5.0	3.0	90 (2.0)

Traffic areas designed to categories F and G shall be posted with the appropriate warning signs, in accordance with clause 6.3.3.1(1)P of the standard.

When a warning sign is not posted, the areas shall be designed to an axle load  $Q_k$  and also to an axle group load equal to 190 kN. The axle group load is distributed evenly to all loaded areas.

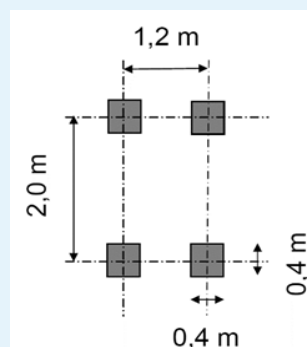

Adjacent parking and roof structures shall be designed, when necessary, also to loads from fire engines and rescue vehicles, and for a concentrated load of both hydraulic platform and extension ladder vehicles where such access is required.

### Instruction

If the structure is designed for vehicle weights higher than category G, the load to be used on the basis of decree of the use of Vehicles on the Road (1257/1992) with amendment 407/2013



is a uniform load corresponding vehicle mass pursuant to decree and as point loads bogie/axle loads corresponding to the vehicle's mass.

## 8. Horizontal loads on parapets and partition walls acting as barriers

**Ministry of the Environment Decree (4/16) concerning national choices for densities, self-weight and imposed loads for buildings, when applying standard SFS-EN 1991-1-1**  
*Section 8 Horizontal loads on parapets and partition walls acting as barriers*

Values for horizontal loads on parapets and partition walls acting as barriers, clause 6.4(1) of the standard, are given in Table 3. Horizontal loads on parapets are not combined with other variable loads.

Table 3. Horizontal loads on parapets and partition walls, line load  $q_k$  and concentrated load  $Q_k$

Loaded area	$q_k$ or $Q_k$
Category A	0.5 kN/m
Category B	0.5 kN/m
Categories C1 to C4 and D	1.0 kN/m
Category C5	3.0 kN/m
Category E	1.0 kN/m
Category F	Annex B
Category G	Annex B

Parapets in categories A to E and panel parts of walls acting as parapets, as well as their fasteners, shall be designed to the concentrated load  $Q_k = 0.3$  kN acting on a random spot. The assumed loaded area for the concentrated load is 50 mm x 50 mm. The concentrated load  $Q_k$  and the line load  $q_k$  do not act simultaneously.

Annex B shall be applied to parapets and barriers in close proximity to car park lanes and ramps subject to impact by a vehicle driving at the speed allowed in the car park. For other parapets and barriers subject to impact from a vehicle that is stopping, an equivalent static load may be used that is assumed to be at least 5 kN in category F and at least 25 kN in category G.

### Instruction

In order to prevent falling accidents, the horizontal load value for category E is the minimum requirement in terms of personnel safety.

## 9. Annex A: Tables for the nominal density of construction materials and the nominal density and angles of response for stored materials

**Ministry of the Environment Decree (4/16) concerning national choices for densities, self-weight and imposed loads for buildings, when applying standard SFS-EN 1991-1-1**  
*Section 9 Annex A: Tables for the nominal density of construction materials and the nominal density and angles of response for stored materials*

The values to be used for the nominal density of construction materials and the nominal density and angles of response for stored materials are those corresponding to real values.

### Instruction

Unless a more detailed report is made, the values in annex A may be replaced by values pursuant to standards EN 1992...EN 1999 or the EN product standards in case these values are presented therein.

A volume weight of 5.0 kN/m<sup>3</sup> is applied instead of the product standards to dry coniferous timber or construction materials manufactured from it, such as gluelam, glued laminated veneer lumber, veneer and laminboard.

## 10. Annex B: Vehicle barriers and parapets for car parks

**Ministry of the Environment Decree (4/16) concerning national choices for densities, self-weight and imposed loads for buildings, when applying standard SFS-EN 1991-1-1**  
*Section 10 Annex B: Vehicle barriers and parapets for car parks*

Annex B shall be used when designing structures for impact barriers.

### Instruction

Dimensioning according to annex B can be performed in accidental design situation. Vehicle barrier's substantial deformation ability absorbs efficiently car's kinetic energy and as well reduces impact load.

# National Annex to standard SFS-EN 1991-1-2: Actions on structures.

## Part 1-2: General actions. Actions on structures exposed to fire

### 1. Scope

**Ministry of the Environment Decree (5/16) concerning national choices for actions on structures exposed to fire, when applying standard SFS-EN 1991-1-2**

*Section 1 Scope*

This Decree is applied in the selection of actions on structures exposed to fire and is used in conjunction with the latest version of standard SFS-EN 1991-1-2.

#### Instruction

As regards standard SFS-EN 1991-1-2, the recommended values set forth in standard SFS-EN 1991-1-2 and all the annexes to standard SFS-EN 1991-1-2 are followed unless otherwise stated in this National Annex.

National choice is permitted in the following clauses of standard SFS-EN 1991-1-2:

- 2.4(4), Note 1, Section 2
- 2.4(4), Note 2, Section 2
- 3.1(10), Section 3
- 3.3.1.2(1), Note 1
- 3.3.1.3(1)
- 3.3.2(2)
- 4.2.2(2)
- 4.3.1(2), Section 4.

A national choice has been made in the clauses marked •.

### 2. Temperature analysis

**Ministry of the Environment Decree (5/16) concerning national choices for actions on structures exposed to fire, when applying standard SFS-EN 1991-1-2**

*Section 2 Temperature analysis*

Instead of the method in Annex F, the National Building Code of Finland concerning fire safety in buildings shall be applied to the equivalent time of fire exposure.

Instruction

### **Temperature analysis**

#### 2.4(4) Note 1

The specific period of time pursuant to clause 2.4(4), Note 1 of the standard is determined according to the National Building Code of Finland's part discussing the fire safety of buildings.

#### 2.4(4) Note 2

As regards the fire resistance period pursuant to clause 2.4(4), Note 2 of the standard, the regulations and guidelines concerning the assumed development of the fire issued in the National Building Code of Finland's section on the fire safety of buildings are followed.

## **3. Thermal loads to be used in temperature analysis**

**Ministry of the Environment Decree (5/16) concerning national choices for actions on structures exposed to fire, when applying standard SFS-EN 1991-1-2**

*Section 3 Thermal loads to be used in temperature analysis*

When a building is designed and constructed in compliance with the fire classes and numerical values given in the regulations and guidelines of the National Building Code of Finland concerning fire safety in buildings, a temperature-time curve of a standard fire in accordance with clause 3.2.1(1) of the standard shall be used. When a building is designed and constructed based on design fire scenarios covering the likely situations in the building, natural fire models or other nominal temperature-time curves may be used.

Instruction

### **General rules**

#### 3.1(10)

The note to clause 3.1(10) provides the opportunity to regulate the use of the nominal temperature/time curves pursuant to clause 3.2 or the natural fire models pursuant to clause 3.3. The designer may select the practice to be used in each case.

## 4. Combination rules for actions

**Ministry of the Environment Decree (5/16) concerning national choices for actions on structures exposed to fire, when applying standard SFS-EN 1991-1-2**  
*Section 4 Combination rules for actions*

The representative value of the variable action shall be taken as the quasi-permanent value  $\psi_{2,1} Q_1$  during fire exposure, in accordance with clause 4.3.1(2) of the standard. The frequent value  $\psi_{1,1} Q_1$  shall be used however for snow, ice and wind loads, in compliance with the national choices set out in standard SFS-EN 1990.

## 5. Annex E: Fire load densities

**Ministry of the Environment Decree (5/16) concerning national choices for actions on structures exposed to fire, when applying standard SFS-EN 1991-1-2**  
*Section 5 Annex E — Fire load densities*

Only E.4 Rate of heat release  $Q$  of Annex E may be applied.

## 6. Annex F: Equivalent time of fire exposure

**Ministry of the Environment Decree (5/16) concerning national choices for actions on structures exposed to fire, when applying standard SFS-EN 1991-1-2**  
*6 § Annex F — Equivalent time of fire exposure*

Annex F is not applied.

# National Annex to standard SFS-EN 1991-1-3: Actions on structures.

## Part 1-3: General actions. Snow loads

### 1. Scope

**Ministry of the Environment Decree (6/16)**  
**concerning national choices for snow loads, when applying standard SFS-EN 1991-1-3**  
*Section 1 Scope*

This Decree is applied in the selection of snow loads and is used in conjunction with the latest version of standard SFS-EN 1991-1-3.

### 2. Snow load on the ground

#### Instruction

As regards standard SFS-EN 1991-1-3, the recommended values set forth in standard SFS-EN 1991-1-3 and all the annexes to standard SFS-EN 1991-1-3 are followed unless otherwise stated in this National Annex.

National choice is permitted in the following clauses of standard SFS-EN 1991-1-3:

- 1.1(2)
- 1.1(3)
- 1.1(4)
- 2(3)
- 2(4)
- 3.3(1), Note 2
- 3.3(2)
- 3.3(3), Note 2
- 4.1(1), Note 1, Section 2
- 4.1(1), Note 2
- 4.1(2), Note 1
- 4.2(1)
- 4.3(1)
- 5.2(2)
- 5.2(5), Note 2
- 5.2(6)
- 5.2(7), Section 3
- 5.2(8)
- 5.3.1(1)
- Note of Table 5.2
- 5.3.2(2)
- 5.3.3(4)
- 5.3.4(3)
- 5.3.4(4), Section 4
- 5.3.5(1), Note 1
- 5.3.4(1), Note 2
- 5.3.5(3), Section 5

- 5.3.6(1), Note 1, Section 6
- 5.3.6(1), Note 2, Section 6
- 5.3.6(3)
- 6.2(2), Section 7
- 6.3(1), Section 8
- 6.3(2), Section 8
- A(1) (Table A1), Section 9.

A national choice has been made in the clauses marked •.

**Ministry of the Environment Decree (6/16)**  
**concerning national choices for snow loads, when applying standard SFS-EN 1991-1-3**  
*Section 2 Snow load on the ground*

The characteristic values for snow load on the ground, in accordance with clause 4.1(1) of the standard, are given in Figure 1. The values given in the figure are minimum values.

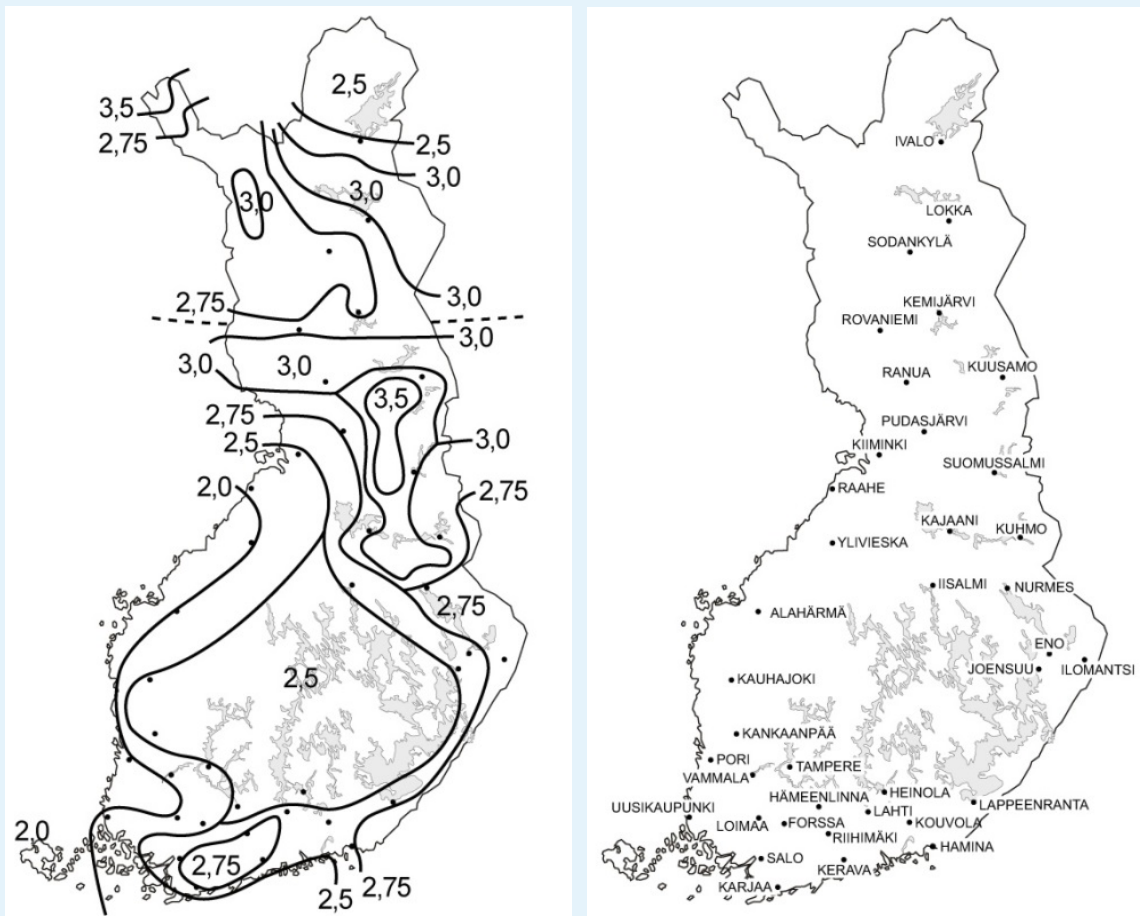

**Figure 1.** Characteristic values for snow load on the ground, in units of kN/m<sup>2</sup>. If the construction site is located in an area where the value is not constant, the intermediate values are obtained by linear interpolation in proportion to distances from the closest curves.

### 3. Snow load on roofs

**Ministry of the Environment Decree (6/16)**  
**concerning national choices for snow loads, when applying standard SFS-EN 1991-1-3**  
*Section 3 Snow load on roofs*

For different topography, the value of exposure coefficients given in table 5.1 clause 5.2(7) of the standard shall be used. For large roofs, where the smaller horizontal dimension of the roof is 50 m or more, and the topography is windswept, the value of the exposure coefficient shall be at least 1.

For different topographies, where the smaller horizontal dimension of the roof is at least 50 m, the exposure coefficient shall be increased based on the smaller horizontal dimension and side ratio, according to the factors in Table 1.

**Table 1.** Factors to be used for increasing the exposure coefficient for snow load on roofs, where the smaller horizontal dimension is at least 50 m.

Smaller dimension (m)	Ratio of larger to smaller dimension	
	1	2
50	1.0	1.1
75	1.1	1.2
100	1.2	1.25

In determining the snow load, in accordance with clause 5.2(8) of the standard, when the thermal insulating properties of the roof structure are insignificant, the thermal coefficient  $C_t$  may be reduced on the basis of a more exact study. The value to be used for snow load  $s$ , however, is at least 0.5 kN/m<sup>2</sup>.

#### Instruction

The removal of snow from the roof or the redistribution of snow, clause 5.2(5) of the standard, is taken into account by designing the roof with the appropriate load arrangements. When dimensioning continuous structures, the uneven removal of snow from a roof is taken into account by means of a load arrangement where the snow load varies between 50% and 100% in different fields.

#### Load arrangements

##### 5.2(7)

The values of the wind protection coefficient  $C_e$  are set forth in Table 2. If the smaller dimension of the roof is larger than 50 m, the values in the table will be multiplied by the coefficients in Table 1.



**Table 2.** Values for the roof wind protection coefficient  $C_e$

Topography	$C_e$
Windswept	0.8 (1.0, if the smaller dimension > 50 m)
Normal	1.0
Sheltered	1.2

Windswept topography: flat unobstructed areas exposed on all sides without or with little shelter afforded by terrain, higher construction works or trees.  
 Normal topography: areas where there is no significant removal of snow by wind at the construction work due to terrain, other construction works or trees.  
 Sheltered topography: areas in which the construction work being considered is significantly lower than the surrounding terrain or surrounded by high trees and/or surrounded by higher construction works.

#### 4. Multi-span roofs

**Ministry of the Environment Decree (6/16)**  
 concerning national choices for snow loads, when applying standard SFS-EN 1991-1-3  
 Section 4 Multi-span roofs

When the slope of the roof is greater than  $60^\circ$  as given in clause 5.3.4(4) of the standard, the value  $\mu_3 = 1.6$  shall be used.

#### 5. Cylindrical roofs

**Ministry of the Environment Decree (6/16)**  
 concerning national choices for snow loads, when applying standard SFS-EN 1991-1-3  
 Section 5 Cylindrical roofs

For cylindrical roofs in clause 5.3.5(3) of the standard, the drifted snow load arrangement to be used is shown in Figure 2, Case (ii).

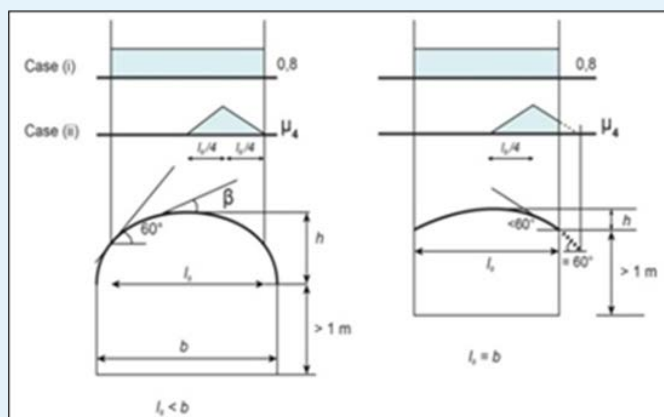

**Figure 2.** Snow load shape coefficients for cylindrical roofs.

Instruction

In Figure 2, Case (ii), the snow load starts from the vertex of the arched roof.

## 6. Roof abutting and close to taller construction works

**Ministry of the Environment Decree (6/16)**  
**concerning national choices for snow loads, when applying standard SFS-EN 1991-1-3**  
*Section 6 Roof abutting and close to taller construction works*

The range of the snow load shape coefficient due to wind  $\mu_w$ , in clause 5.3.6(1) of the standard is:

$0.8 \leq \mu_w \leq 2.5$ , if the area of the lower roof is  $\geq 6 \text{ m}^2$ ;  
 $0.8 \leq \mu_w \leq 1.5$ , if the area of the lower roof is  $2 \text{ m}^2$ ; or  
 $\mu_w = 0.8$ , if the area of the lower roof is  $\leq 1 \text{ m}^2$ .

Intermediate upper values for factor  $\mu_w$  are obtained by linear interpolation when the area of the lower roof is less than  $6 \text{ m}^2$ .

The range of drift length  $l_s$  is  $2 \text{ m} \leq l_s \leq 6 \text{ m}$ .

## 7. Drifting at projections and obstructions

**Ministry of the Environment Decree (6/16)**  
**concerning national choices for snow loads, when applying standard SFS-EN 1991-1-3**  
*Section 7 Drifting at projections and obstructions*

The range of drift length  $l_s$ , given in clause 6.2(2) of the standard, is  $2 \text{ m} \leq l_s \leq 6 \text{ m}$ .

Instruction

The effect of snow overhanging the edge of the roof, clauses 6.3(1) and 6.3(2) of the standard, does not usually need to be considered.

## 8. Annex A: Design situations and load arrangements to be used for different locations

**Ministry of the Environment Decree (6/16)**  
**concerning national choices for snow loads, when applying standard SFS-EN 1991-1-3**  
*Section 8 Annex A: Design situations and load arrangements to be used for different locations*

For Annex A, only normal conditions according to clause 3.2(1) of the standard are applied, with the value  $\mu_i C_e C_t s_k$  to be used in persistent/transient design situations for non-drifted and drifted snow.

The exceptional conditions Case B1, Case B2 and Case B3 do not apply to Finland.

## 9. Annex B: Snow load shape coefficients for exceptional snow drifts

**Ministry of the Environment Decree (6/16)**  
**concerning national choices for snow loads, when applying standard SFS-EN 1991-1-3**  
*Section 9 Annex B: Snow load shape coefficients for exceptional snow drifts*

Annex B is not applied.

## 10. Annex C: European ground snow load maps

**Ministry of the Environment Decree (6/16)**  
**concerning national choices for snow loads, when applying standard SFS-EN 1991-1-3**  
*Section 10 Annex C: European ground snow load maps*

Annex C is not applied.

# National Annex to standard SFS-EN 1991-1-4: Actions on structures.

## Part 1-4: General actions. Wind actions

### 1. Scope

**Ministry of the Environment Decree (7/16)**  
**concerning national choices for wind actions, when applying standard SFS-EN 1991-1-4**  
*Section 1 Scope*

This Decree is applied in the selection of wind actions on structures and is used in conjunction with the latest version of standard SFS-EN 1991-1-4.

#### Instruction

As regards standard SFS-EN 1991-1-4, the recommended values set forth in standard SFS-EN 1991-1-4 and all the annexes to standard SFS-EN 1991-1-4 are followed unless otherwise stated in this National Annex.

*The Non-Contradictory Complementary Information (NCCI) is presented in italics in the instructions.*

National choice is permitted in the following clauses of standard SFS-EN 1991-1-4:

- 1.5(2)
- 4.1(1)
- 4.2(1)P, Note 2, Section 2
- 4.2(2)P, Note 1
- 4.2(2)P, Note 2
- 4.2(2)P, Note 3
- 4.2(2)P, Note 5
- 4.3.1(1), Note 1
- 4.3.1(1), Note 2
- 4.3.2(1), Section 3
- 4.3.2(2)
- 4.3.3(1), Section 4
- 4.3.4(1)
- 4.3.5(1)
- 4.4(1), Note 2
- 4.5(1), Note 1
- 4.5(1), Note 2, Section 5
- 5.3(5)
- 6.1(1)
- 6.3.1(1), Note 3

- 6.3.2(1)
- 7.1.2(2)
- 7.1.3(1)
- 7.2.1(1), Note 2
- 7.2.2(1), Section 6
- 7.2.2(2), Note 1, Section 6
- 7.2.3(2)
- 7.2.3(4)
- 7.2.4(1)
- 7.2.4(3)
- 7.2.5(1)
- 7.2.5(3)
- 7.2.6(1)
- 7.2.6(3)
- 7.2.8(1)
- 7.2.9(2)
- 7.2.10(3), Note 1
- 7.2.10(3), Note 2
- 7.3(6)
- 7.4.1(1)
- 7.4.3(2)
- 7.6(1), Note 1
- 7.7(1), Note 1
- 7.8(1)
- 7.9.2(2)
- 7.9.3(1), Table 7.14
- 7.10(1), Note 1
- 7.11(1), Note 2
- 7.13(1)
- 7.13(2)
- 8.1(1), Note 1
- 8.1(1), Note 2
- 8.1(4)
- 8.1(5)
- 8.2(1), Note 1
- 8.3(1)
- 8.3.1(2)
- 8.3.2(1)
- 8.3.3(1), Note 1
- 8.3.4(1)
- 8.4.2(1), Note 1
- 8.4.2(1), Note 2

- A.2(1) Section 7
- E.1.3.3(1)
- E.1.5.1(1), Note 1, Section 8
- E.1.5.1(1), Note 2
- E.1.5.1(3)
- E.1.5.2.6(1), Note 1
- E.1.5.3(2), Note 1
- E.1.5.3(4)
- E.1.5.3(6)
- E.3(2).

A national choice has been made in the clauses marked •.

Instruction

### Scope

1.1(10)

*Persistent thermal surface inversion occurs in the northern part of Finland every winter. This phenomenon is occasionally also met in other parts of the country. A stratified flow condition may arise during thermal inversion such that high wind velocities prevail above a layer of moderate or no wind. Therefore, additional guidance is given later for the orography factor (clause 4.3.2) and for the calculation of the cross wind amplitude due to vortex shedding (clause E.1.5).*

*The effect of thermal surface inversion can be seen in the wind speeds that correspond to a return period of 50 years.*

## 2. Basic values

**Ministry of the Environment Decree (7/16)**  
**concerning national choices for wind actions, when applying standard SFS-EN 1991-1-4**  
*Section 2 Basic values*

In Finland, the fundamental value of the basic wind velocity  $V_{b,0}$  is 21 m/s, in accordance with clause 4.2(1)P of the standard. This value applies to the entire country, including sea and mountain areas.

Instruction

When used together with the orography factor  $c_o(z)$  and the other instructions provided in standard SFS-EN 1991-1-4, the selected basic value will lead to wind load values that are conservative in the entire country, including mountainous areas. For sea areas, however, an adjustment pursuant to section 3 is required in the value of the terrain factor.

### 3. Terrain roughness

**Ministry of the Environment Decree (7/16)**  
**concerning national choices for wind actions, when applying standard SFS-EN 1991-1-4**  
*Section 3 Terrain roughness*

When determining the roughness factor,  $c_r(z)$ , for terrain category 0, the terrain factor is taken as  $k_r = 0.18$ , instead of the value derived from Equation 4.5.

Instruction

Wind velocity in sea areas would be underestimated if Equation (4.5) were used to obtain the terrain factor. Therefore, the value of  $k_r = 0.18$  arising from statistical data is used for the terrain factor in sea areas.

### 4. Peak velocity pressure

**Ministry of the Environment Decree (7/16)**  
**concerning national choices for wind actions, when applying standard SFS-EN 1991-1-4**  
*Section 4 Peak velocity pressure*

The value of the air density  $\rho$  is the recommended value  $1.25 \text{ kg/m}^3$ , in accordance with clause 4.5(1) of the standard. When designing slender special structures, the value of the air density shall be calculated at the altitude and temperature relevant to the site and load conditions concerned.

Instruction

Note 2 for clause 4.5(1) of the standard

The air density is obtained from the expression:

$$\rho = 353/T * e^{-0.00012 H}$$

where

- $\rho$  is the air density ( $\text{kg/m}^3$ ) at the load condition concerned
- $T$  is the absolute air density (K) at the load condition concerned
- $H$  is the altitude (m) above the sea level at the site

## 5. Pressure and force coefficients for vertical walls of rectangular plan buildings

**Ministry of the Environment Decree (7/16)**  
**concerning national choices for wind actions, when applying standard SFS-EN 1991-1-4**  
*Section 5 Pressure and force coefficients for vertical walls of rectangular plan buildings*

The reference heights,  $z_e$ , for leeward walls and sidewalls, clause 7.2.2(1) of the standard, shall be calculated as for windward walls.

For the values of external pressure coefficients, clause 7.2.2(2) of the standard, when  $h/d$  is greater than 5, the values of coefficients  $c_{pe,10}$  and  $c_{pe,1}$  in row  $h/d = 5$  in Table 7.1 of the standard shall be used.

## 6. Annex A: Terrain effects

**Ministry of the Environment Decree (7/16)**  
**concerning national choices for wind actions, when applying standard SFS-EN 1991-1-4**  
*Section 6 Annex A: Terrain effects*

For the transition between terrain categories, Procedure 1 under clause A.2(1) in Annex A to the standard shall be followed.

Instruction

*The recommended values of the upwind distance can be redefined if reliable data is available on the wind speeds in the transitional area between two terrain categories.*

*The procedure 1 described in Annex A.2 is the preferred method to deal with the transition between terrain categories. In coastal city areas, however, the application of this method may lead to sudden and large discrepancies in the design of wind actions on adjacent buildings. In such conditions, the concept of the displacement height described in Annex A.5 of standard SFS-EN 1991-1-4 can be applied. The transitional area of the terrain categories can also be specified by using reliable measured data on wind velocities.*

## 7. Annex E: Vortex shedding and aeroelastic instabilities

**Ministry of the Environment Decree (7/16)**  
**concerning national choices for wind actions, when applying standard SFS-EN 1991-1-4**  
*Section 7 Annex E: Vortex shedding and aeroelastic instabilities*

A stratified flow condition is possible in most parts of the country. Therefore, of the approaches given in Annex E, clause E.1.5.1(1) of the standard, the approach given in clause E.1.5.3 shall be used.



## Instruction

*Vortex shedding occurs when vortices are shed alternately on opposite sides of the structure. This causes a variable load that is perpendicular to the direction of the wind. The structure may begin to vibrate if the frequency of the shedding of the vortices is the same as the natural frequency of the structure.*

*The dynamic excitation due to vortex shedding may be amplified if the wind flow is laminar. These kinds of conditions that promote large amplitude vibrations have been met in Central Europe. Laminar wind flows are typical in conditions of temperature inversion, which is common in Finland. The calculation method presented in annex E.1.5.3 takes account of this amplification. However, the method presented in annex 1.5.2 does not have this characteristic. Therefore, the method described in E.1.5.3 is preferred in Finland.*

# National Annex to standard SFS-EN 1991-1-5: Actions on structures.

## Part 1-5: General actions. Thermal actions

### 1. Scope

**Ministry of the Environment Decree (8/16)**  
**concerning national choices for thermal actions, when applying standard SFS-EN 1991-1-5**  
*Section 1 Scope*

This Decree is applied when selecting thermal actions and is used together with the latest version of standard SFS-EN 1991-1-5.

#### Instruction

As regards standard SFS-EN 1991-1-5, the recommended values set forth in standard SFS-EN 1991-1-5 and all the annexes to standard SFS-EN 1991-1-5 are followed unless otherwise stated in this National Annex.

National choice is permitted in the following clauses of standard SFS-EN 1991-1-5:

- 5.3(2) (Tables 5.1, 5.2 and 5.3), Section 2, Section 3
  - 6.1.1(1), Note 2
  - 6.1.2(2)
  - 6.1.3.1(4)
  - 6.1.3.2(1)P
  - 6.1.3.3(3), Note 2
  - 6.1.4(3)
  - 6.1.4.1(1)
  - 6.1.4.2(1), Note 1
  - 6.1.4.3(1)
  - 6.1.4.4(1)
  - 6.1.5(1), Note 1
  - 6.1.6(1)
  - 6.2.1(1)P
  - 6.2.2(1)
  - 6.2.2(2), Note 1
  - 7.2.1(1)P
  - 7.5(3), Note 1
  - 7.5(4)
- A.1(1), Note 1, Section 4
- A.1(3) Section 4
  - A.2(2), Note 1

- B(1) (Tables B.1, B.2 and B.3).

A national choice has been made in the clauses marked •.

## 2. Indicative temperatures of the inner environment

**Ministry of the Environment Decree (8/16)**  
**concerning national choices for thermal actions, when applying standard SFS-EN 1991-1-5**  
*Section 2 Indicative temperatures of the inner environment*

$T_1 = 25$  °C (summer) and  $T_2 = 23$  °C (winter) are used as temperature values in accordance with the values in Table 5.1 of clause 5.3(2) of the standard.

## 3. Indicative temperatures for buildings above ground level

**Ministry of the Environment Decree (8/16)**  
**concerning national choices for thermal actions, when applying standard SFS-EN 1991-1-5**  
*Section 3 Indicative temperatures for buildings above ground level*

The values in Table 5.2 of clause 5.3(2) of the standard for indicative temperatures for buildings above ground level shall apply as follows.

The temperature values specified in the isotherm maps in Figures 1 and 2 are used for maximum shade air temperature ( $T_{\max}$ ) and minimum shade air temperature ( $T_{\min}$ ).

For values of solar radiation effects  $T_3$ ,  $T_4$  and  $T_5$ ,  $T_3 = 5$  °C,  $T_4 = 10$  °C and  $T_5 = 15$  °C are used for structural elements facing north and east.

The following values are used for structural elements facing south and west or for horizontal structural elements:

- 1)  $T_3 = 10$  °C,  $T_4 = 20$  °C and  $T_5 = 30$  °C for structures with a large outer insulation mass (e.g. concrete sandwich structures); or
- 2)  $T_3 = 18$  °C,  $T_4 = 30$  °C and  $T_5 = 42$  °C for structures with a small outer insulation mass (e.g. sandwich structure with a sheet metal surface).

When the absorption factor has been determined, the temperature may be selected on the basis of the absorption factor, regardless of the surface colour.

## 4. Indicative temperatures for underground parts of buildings

**Ministry of the Environment Decree (8/16)**  
**concerning national choices for thermal actions, when applying standard SFS-EN 1991-1-5**  
*Section 4 Indicative temperatures for underground parts of buildings*

For indicative temperatures for underground parts of buildings, the values in Table 5.3 of clause 5.3(2) of the standard shall be applied, where  $T_6 = 6$  °C,  $T_7 = 4$  °C,  $T_8 = -7$  °C and  $T_9 = -4$  °C.

## 5. Isotherms of minimum and maximum shade air temperatures

**Ministry of the Environment Decree (8/16)**  
**concerning national choices for thermal actions, when applying standard SFS-EN 1991-1-5**  
*Section 5 Isotherms of minimum and maximum shade air temperatures*

Data on annual minimum and annual maximum shade air temperature, in accordance with A.1(1) of the standard, are given in Figures 1 and 2.

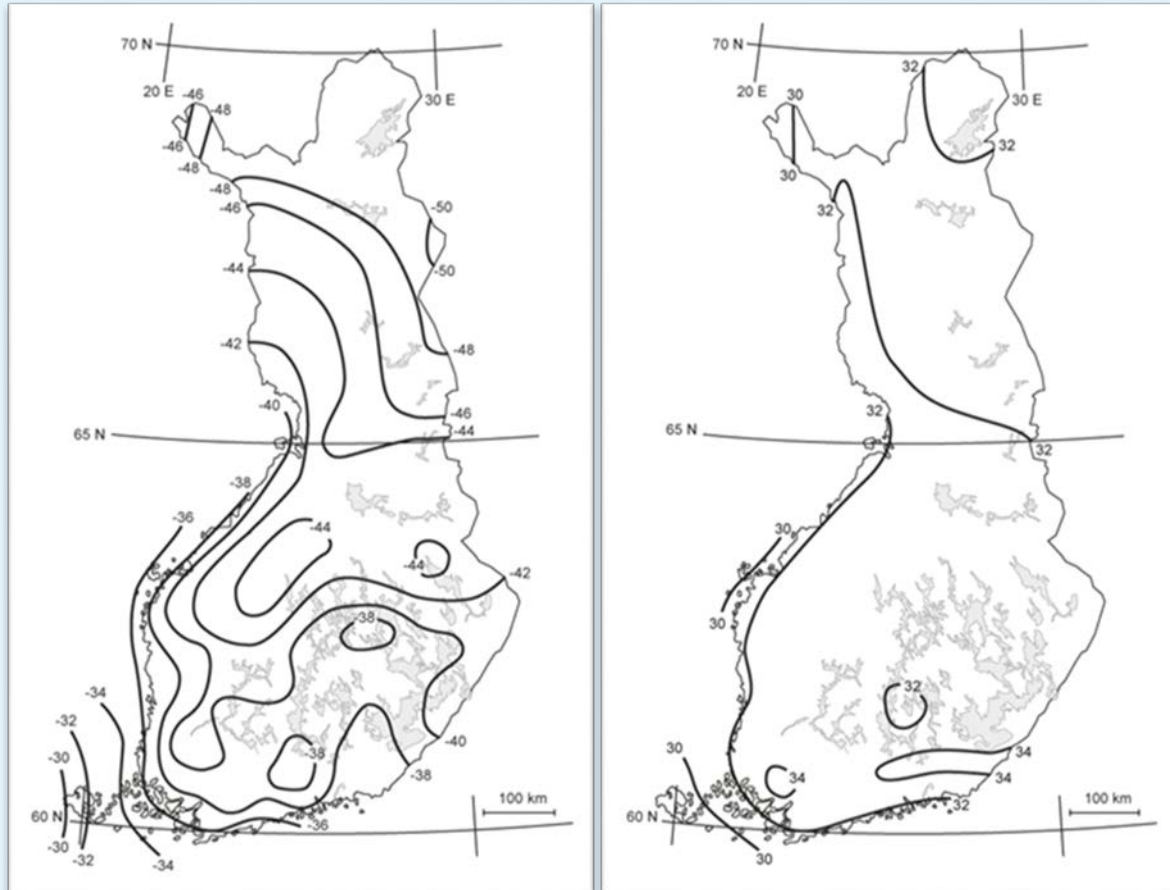

**Figure 1.** Isotherms of the minimum shade air temperature (°C). Considerable local deviations may occur depending on the topography and the built environment.

**Figure 2.** Isotherms of the maximum shade air temperature (°C). Considerable local deviations may occur depending on the topography and the built environment.

The minimum shade air temperatures represent values with an annual probability of falling below of 0.02, and the maximum shade air temperatures represent values with an annual probability of being exceeded of 0.02.'

The values of shade air temperature may be adjusted for height above sea level by subtracting 0.5°C per 100 m of height for minimum shade air temperatures and 1.0°C per 100 m of height for maximum shade air temperatures.

Unless other information is available, the value of 10°C is used for the initial temperature  $T_0$ , as specified in A.1(3) of Annex A to the standard.

# National Annex to standard SFS-EN 1991-1-6: Actions on structures.

## Part 1-6: General actions. Execution-time actions

### 1. Scope

Ministry of the Environment Decree (9/16) concerning national choices for actions during execution, when applying standard SFS-EN 1991-1-6  
*Section 1 Scope*

This Decree is applied in the selection of actions during execution and is used in conjunction with the latest version of standard SFS-EN 1991-1-6.

#### Instruction

As regards standard SFS-EN 1991-1-6, the recommended values set forth in standard SFS-EN 1991-1-6 and all the annexes to standard SFS-EN 1991-1-6 are followed unless otherwise stated in this National Annex.

*The Non-Contradictory Complementary Information (NCCI) is presented in italics in the instructions.*

National choice is permitted in the following clauses of standard SFS-EN 1991-1-6:

- 1.1(3)
- 2.2(4), Note 1, Section 2
- 3.1(1)P, Section 3
- 3.1(5), Note 1, Section 3
- 3.1(5), Note 2, Section 3
- 3.1(7), Section 3
- 3.1(8), Note 1, Section 4
- 3.3(2), Section 5
- 3.3(6), Section 5
- 4.9(6), Note 2
- 4.10(1)P, Section 6
- 4.11.1(2) (Table 4.1), Note 1, Section 7
- 4.11.1(2) (Table 4.1), Note 3, Section 7
- 4.11.2(1), Note 2
- 4.12(1)P, Note 2, Section 8
- 4.12(2), Section 8
- 4.12(3), Section 8
- 4.13(2)
- A1.1(1), Note 2, Section 9
- A1.3(2) Section 9

- A2.3(1), Note 1
- A2.4(2)
- A2.4(3)
- A2.5(2)
- A2.5(3).

A national choice has been made in the clauses marked •.

## 2. Construction loads

**Ministry of the Environment Decree (9/16)**  
**concerning national choices for actions during execution, when applying standard SFS-EN 1991-1-6**  
*Section 2 Construction loads*

The limits of the area where construction loads may be moved shall be marked in the plans, in accordance with clause 2.2(4) of the standard, when the magnitude of the actions is significant in terms of the structure.

### Instruction

Significant loads may be caused by, for example, heavy equipment, heavy moving machinery, storage of goods or demolition waste, filling and excavation work, supporting moulds for upper floors and casting work.

### 3. Design situations to be verified

**Ministry of the Environment Decree (9/16)**  
**concerning national choices for actions during execution, when applying standard SFS-EN 1991-1-6**  
*Section 3 Design situations to be verified*

The design situation for wind actions during exceptional weather conditions shall be interpreted as an accidental design situation, in accordance with clause 3.1(1)P of the standard.

There are no recommended values for return periods in clause 3.1(5) of the standard for the determination of characteristic values of variable actions during execution regarding the nominal duration of a design situation lasting no more than three days.

In the determination of the characteristic values of variable actions, in accordance with clause 3.1(5) of the standard, a nominal duration of three days, to be chosen for short execution phases, corresponds to the extent in time of reliable meteorological predictions for the location of the construction site. In such a case, the magnitude of the action shall be chosen according to the meteorological predictions. The minimum value to be used for the fundamental value of the basic wind velocity is 10 m/s.

The fundamental value of the basic wind velocity  $v_{b,0}$  during the execution for a nominal duration of up to three months is 18 m/s, in accordance with clause 3.1(5) of the standard, and this may be applied in the entire country, including sea and mountain areas.

For the combination of snow loads and wind actions, in accordance with clause 3.1(7) of the standard, no reductions are allowed if the snow loads and wind actions that are used are less than in persistent design situations.

#### Instruction

In the determination of snow load during the execution, the seasonal variation, length of the execution phase and removal of snow may be taken into account. However, when the snow load can occur, the minimum value of the load  $s$  should be at least 0.5 kN/m<sup>2</sup>. The load  $s$  is the load on the roof or on the structure. During the execution, when the snow load is affecting the floors and not the roof, the load may be taken as uniformly distributed and e.g. drifting due to obstacles need not to be taken into account.

#### Instruction

The peak velocity pressure during the execution for a nominal duration of up to three months is 75% of the value for the persistent design situation. For the wind load, this corresponds to a 5-year return period.

## 4. Imperfections and restraint actions

**Ministry of the Environment Decree (9/16)**  
**concerning national choices for actions during execution, when applying standard SFS-EN 1991-1-6**  
*Section 4 Imperfections and restraint actions*

For a persistent design situation during execution, in accordance with clause 3.1(8) of the standard, the imperfections in the geometry of the structure and of structural members shall be those imperfections due to normal use of the completed structure.

The imperfections to be defined, however, shall be determined on a project-by-project basis when the execution includes stages where a structure or a structural member has an imposed load in a different position or location than when the structure or the structural member is in the final state.

The imperfections caused by restraint actions and their deflections during erection work shall be taken into consideration. The imperfections caused by deflections in auxiliary construction works shall be taken into account if they differ from the imperfections of the persistent design situation.

## 5. Serviceability limit states

**Ministry of the Environment Decree (9/16)**  
**concerning national choices for actions during execution, when applying standard SFS-EN 1991-1-6**  
*Section 5 Serviceability limit states*

Any deformation during execution shall not cause damage to adjacent structures nor to the surface materials of the structural members, in accordance with clause 3.3(2) of the standard. The deformation during execution can, however, be greater than the allowed deformation for the completed structure if the deformation is reversible when the actions due to execution are removed.

The design situation during execution, compared to the persistent design situation, shall not cause larger crack widths in the structure and the cracking shall not reduce the stiffness of the structure, if this has not been taken into consideration in the persistent design situation.

Auxiliary construction works shall be designed so that the tolerances of the completed structure are not exceeded, in accordance with clause 3.3(6) of the standard.

## 6. Actions due to atmospheric icing

**Ministry of the Environment Decree (9/16)**  
**concerning national choices for actions during execution, when applying standard SFS-EN 1991-1-6**  
*Section 6 Actions due to atmospheric icing*

Actions due to atmospheric icing shall be determined on a project-by-project basis, in accordance with clause 4.10(1)P of the standard.

Instruction

The determination of ice loads is presented in the standards EN 1993-3 and ISO 12494.



## 7. Construction loads

**Ministry of the Environment Decree (9/16)**  
**concerning national choices for actions during execution, when applying standard SFS-EN 1991-1-6**  
*Section 7 Construction loads*

When considering construction loads, clause 4.11.1(1), Note 1 of the standard, the characteristic value of load  $q_{ca,k}$  is 1.0 kN/m<sup>2</sup>. The characteristic value of load  $q_{ca,k}$  for precast slabs before grouting is 0.5 kN/m<sup>2</sup>.

The characteristic values of loads  $q_{cb}$  and  $F_{cb}$  for the actions caused by the temporary storage of material are determined on a project-by-project basis, in accordance with clause 4.11.1(1), Note 3 of the standard.

## 8. Accidental actions

**Ministry of the Environment Decree (9/16)**  
**concerning national choices for actions during execution, when applying standard SFS-EN 1991-1-6**  
*Section 8 Accidental actions*

The dynamic amplification factor in accidental design situations is 2, in accordance with clause 4.12(1)P, Note 2 of the standard.

The dynamic effects, clause 4.12(2) of the standard, are determined on a project-by-project basis. Actions due to equipment falling or the dropping of equipment are taken into account where there is an exceptionally demanding work stage or structure, and where the equipment falling or the dropping of equipment will cause a disproportionately large amount of damage in relation to the initial incident.

Structures shall be designed to take into account a human impact load as an accidental action, when stumbling could lead to a person falling or when the structure under consideration has to prevent the fall of a person.

The design values of the human impact force to be used in the accidental design situation, clause 4.12(3) of the standard, are:

- 1) 2.5 kN applied over an area of 200 mm x 200 mm; this design value takes into account a situation where a possible stumble does not lead to a person falling due to the collapse of the structure; or
- 2) 10.0 kN applied over an area of 300 mm x 300 mm or the action is applied to fastening points for safety devices. This is to verify the design of protective structures, and the resistance of the fastenings, that will prevent the fall of a person.

Instruction

### The design of fixed fastening points for safetylines on roofs

Roof accessories and roof safety products to which persons working on roofs will fasten their safetylines are designed for the load caused by the falling of a person.

The durability of the fitting or rooftop safety product and its fastening and substructure are verified by means of either testing or computational analysis. Testing is performed by means of a drop test pursuant to clause 8.2 of standard SFS-EN 516. The computational analysis is

performed in an accidental situation by using a design value of  $A_d = 10$  kN for the accidental action, acting in an arbitrary direction at the roof surface level at the height of the lifeline fastening point. The analysis does not need to account for other variable actions that may impact at the same time.

If the rooftop safety products are CE labelled and designed for the fastening of a safetyline, only the durability of the substructure needs to be verified.

#### The design of fixed fastening points for lifelines during the installation of the load bearing system

The fastening points for safetylines required during installation are designed for the load caused by a falling person.

The durability of the fastening point and substructure may be verified by means of either testing or computational analysis. Testing is performed by means of a drop test pursuant to clause 8.2 of standard SFS-EN 516. The computational analysis is performed in an accidental situation by using a design value of  $A_d = 10$  kN for the accidental action, acting at the safetyline fastening point in the direction of the lifeline at the moment of falling. The analysis does not need to account for other variable actions that may impact at the same time.

#### Design of removable and transferable fastening points

*Removable and transferable fastening points are covered by the directive on personal protective equipment, and the requirements for the fastening point are set forth in standard SFS-EN 795.*

## 9. Annex A: Supplementary rules for buildings

**Ministry of the Environment Decree (9/16)**  
**concerning national choices for actions during execution, when applying standard SFS-EN 1991-1-6**  
*Section 9 Annex A: Supplementary rules for buildings*

For ultimate limit state verifications, in clause A1.1(1), Note 2 of the standard, the recommended value to be used for the combination factor  $\psi_0$  for the variable action due to construction loads is 1.0, and the recommended value for the quasi-permanent combination factor  $\psi_2$  for the variable action is 0.3.

The characteristic value of equivalent horizontal forces, clause A1.3(2) of the standard, is 3% of the vertical loads from the most unfavourable combination of actions. A lower value can be used if skewness of the vertical action during the execution can be estimated.

When casting concrete, it shall be assumed that a variable horizontal point load acts in a random direction on the surface level of cast concrete, with a characteristic value of 1.5 kN.

# National Annex to standard SFS-EN 1991-1-7: Actions on structures.

## Part 1-7: General actions. Accidental actions

### 1. Scope

**Ministry of the Environment Decree (10/16)**  
**concerning national choices for accidental actions, when applying standard SFS-EN 1991-1-7**  
*Section 1 Scope*

This Decree is applied in the selection of accidental actions and is used in conjunction with the latest version of standard SFS-EN 1991-1-7.

#### Instruction

As regards standard SFS-EN 1991-1-7, the recommended values set forth in standard SFS-EN 1991-1-7 and all the annexes to standard SFS-EN 1991-1-7 are followed unless otherwise stated in this National Annex.

National choice is permitted in the following clauses of standard SFS-EN 1991-1-7:

- 2(2), Section 2
- 3.1(2), Note 4, Section 3
- 3.2(1), Note 3
- 3.3(2), Note 2, Section 4
- 3.3(2), Note 3, Sections 6 and 7
- 3.4(1), Note 4, Section 5
- 3.4(2)
- 4.1(1), Note 1
- 4.1(1), Note 3
- 4.3.1(1), Note 1, Section 8
- 4.3.1(1), Note 2, Section 8
- 4.3.1(1), Note 3, Section 8
- 4.3.1(2), Section 8
- 4.3.1(3)
- 4.3.2(1), Note 1
- 4.3.2(1), Note 3
- 4.3.2(1), Note 4
- 4.3.2(2)
- 4.3.2(3)
- 4.4(1), Section 8
- 4.5(1)
- 4.5.1.2(1), Note 1
- 4.5.1.2(1), Note 2

- 4.5.1.4(1)
- 4.5.1.4(2)
- 4.5.1.4(3)
- 4.5.1.4(4)
- 4.5.1.4(5), Section 8
- 4.5.1.5(1), Section 8
- 4.5.2(1)
- 4.5.2(4)
- 4.6.1(3), Note 1
- 4.6.2(1)
- 4.6.2(2)
- 4.6.2(3), Note 1
- 4.6.2(4)
- 4.6.3(1)
- 4.6.3(3)
- 4.6.3(4)P
- 4.6.3(5), Note 1
- 5.3(1)P
- A.4(1), Note 1.

A national choice has been made in the clauses marked •.

## 2. Accidental action

**Ministry of the Environment Decree (10/16)**  
**concerning national choices for accidental actions, when applying standard SFS-EN 1991-1-7**  
*Section 2 Accidental action*

An accidental action, clause 2(2) of the standard, is considered a fixed action in those cases where the load is evenly distributed on the entire structure.

### 3. Accidental design situations

**Ministry of the Environment Decree (10/16)**  
**concerning national choices for accidental actions, when applying standard SFS-EN 1991-1-7**  
*Section 3 Accidental design situations*

The designer of a structure shall devise a strategy such that neither the whole building nor a significant part of it will collapse if localised failure is sustained.

The adoption of this strategy shall provide a building with sufficient robustness to not succumb to various types of unspecified accidental actions.

The minimum period that a structure needs to remain intact following an accident should be that period needed to facilitate the safe evacuation and rescue of personnel from the building and its surroundings. Buildings used for handling hazardous materials, for providing essential services or for national security reasons may need to remain intact for longer periods.

The party engaging the building project is not permitted, without the consent of the relevant authorities, in accordance with clause 3.1(2), Note 4 of the standard, to agree to the use of lower values for accidental actions in individual projects other than those given in SFS-EN 1991-1-7 and in this Decree.

### 4. Accidental design situations – strategies for limiting the extent of localised failure

**Ministry of the Environment Decree (10/16)**  
**concerning national choices for accidental actions, when applying standard SFS-EN 1991-1-7**  
*Section 4 Accidental design situations — strategies for limiting the extent of localised failure*

The acceptable limit of 'localised failure', in accordance with clause 3.3(2), Note 2 of the standard, depends on the type of building:

- 1) In multi-storey buildings, the localised failure may not exceed 15% of the floor area or 100 m<sup>2</sup>/storey. The failure may occur in two adjacent storeys; or
- 2) If a column is damaged in hall-type buildings, the acceptable limit of localised failure is the length of the main girders supported by the column, multiplied by two times the distance between the main girders. If the main girders are on the external wall line, the acceptable limit of localised failure is the combined length of the main girders, multiplied by the distance between the main girders.

If the main girder of a hall-type building is an arch or similar structure that does not have separate columns, the extent of localised failure may be the length of the main girder, multiplied by two times the distance between the main girders. If the main girder is on the external wall line, the acceptable limit of localised failure is the length of the main girder, multiplied by the distance between the main girders.

If load-bearing walls form the vertical frame of a hall-type building, the localised failure may not exceed the length of the horizontal structures supported by the wall, multiplied by  $2H$ , where  $H$  is the height of the load-bearing wall.

In hall-type buildings, the failure may occur on one storey only.

Instruction

Multi-storey buildings

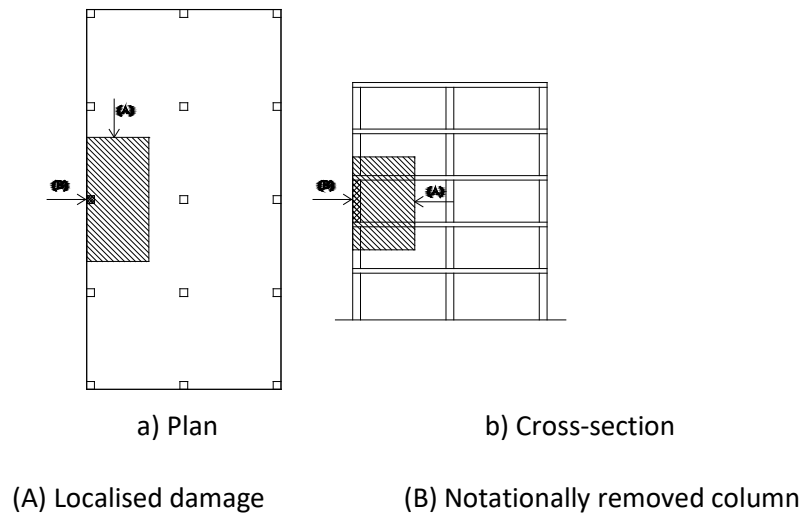

**Figure 1.** Acceptable limit of localised damage in multi-storey buildings

In multi-storey buildings, localised damage (initial collapse) will easily lead to a continuous collapse. If the extent of localised damage cannot be reliably assessed, localised damage cannot be allowed. In this case, the building shall be designed pursuant to section 6, using either tying systems or alternative load transfer routes.

Hall-type buildings

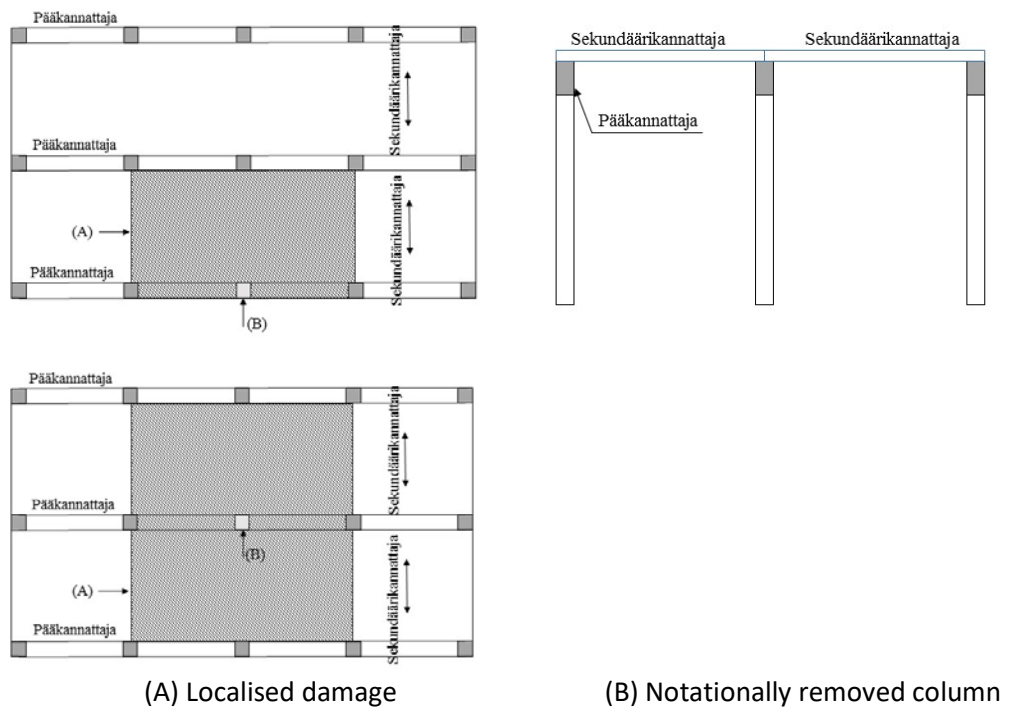

**Figure 2.** Acceptable limit of localised damage in hall-type buildings, two-span hall used as an example

## 5. Accidental design situations – use of consequences classes

**Ministry of the Environment Decree (10/16)**  
**concerning national choices for accidental actions, when applying standard SFS-EN 1991-1-7**  
*Section 5 Accidental design situations — use of consequences classes*

In the testing of accidental design situations to verify that a building or structure can remain intact, the Ministry of the Environment Decree concerning national choices for consequences classes, in accordance with standard SFS-EN 1990, shall apply. For the strategies for accidental design situations, in accordance with clause 3.4(1) of SFS-EN 1991-1-7, consequences classes CC2 and CC3 are divided into subclasses *a* and *b* based on the size of buildings and structures. The possible consequences are greater in subclass *b* than in subclass *a*.

### Instruction

In an accidental limit state, the consequences class selected for the building pursuant to the national annex to standard SFS-EN 1990 is divided into subclasses for the selection of the principle of operation laid down in item 3.4(1) of the standard as follows:

- 1) Consequences class CC1 includes 1- and 2-storey buildings which are only occasionally occupied by people, such as warehouses.
- 2) Consequences class CC2 subclass *a*, lower group, includes buildings with a maximum of four aboveground floors or whose height from the ground is a maximum of 16 m. However, residential buildings with a maximum of two aboveground floors may be designed pursuant to consequences class 1 in an accidental limit state.
- 3) Consequences class CC2 subclass *b*, upper group, includes all other buildings and structures that are not in consequences classes 1, 2a or 3.
- 4) Consequences class CC3 subclass *a* includes residential buildings, office buildings, commercial buildings with 9–15 storeys and other buildings with 9–15 storeys with a similar intended use and load bearing system. The number of storeys includes any basement storeys.
- 5) Consequences class CC3 subclass *b* includes
  - a) other buildings with more than 8 storeys, including a possible basement
  - b) concert halls, theatres, sports and exhibitions halls and spectator galleries
  - c) heavily loaded buildings or buildings with large spans that are often occupied by a large number of people
  - d) special structures according to a case-by-case assessment

## 6. Principles for ensuring the robustness of a building

**Ministry of the Environment Decree (10/16)**  
**concerning national choices for accidental actions, when applying standard SFS-EN 1991-1-7**  
*Section 6 Principles for ensuring the robustness of a building*

Sufficient robustness for a multi-storey building shall be ensured, in accordance with clause 3.3(2), Note 3 of the standard, by applying three-dimensional tying for additional integrity or designing alternative load transfer path.

The tying system shall be designed to increase the robustness and integrity of a building in the event of higher damage consequences.

Alternative load paths shall be designed so that a localised failure does not exceed the limits given in section 4.

When an alternative load path cannot be found or when such a method would lead to unreasonable structural solutions with regard to technical functionality, a method of designing key elements in accordance with clause 3.3(2)(a) of the standard may be used, thus considerably increasing the robustness of the building.

In the designing of key elements, in accordance with clause 3.3(2), Note 1 of the standard, accidental action  $A_d$  shall be determined by carrying out a risk assessment and the grounds for the values used shall be included and recorded in the design documentation. Alternatively, the values recommended in the standard may be used.

For buildings in consequences class CC3b, a systematic risk assessment of the building shall be undertaken, taking into account both foreseeable and unforeseeable hazards. If accidental actions can be determined by the risk assessment, they shall be taken into consideration in the design. Accidental actions include linear loads, concentrated loads, weight loads, deformations or deformation forces.

### Instruction

#### **Design of tying systems and calculating tying forces in different consequences classes.**

##### Buildings in consequences class CC1:

Provided that a building has been designed and constructed in accordance with the rules given in SFS-EN 1990...SFS-EN 1999 for satisfying the requirements of normal design situation, no further specific consideration is necessary with regard to accidental actions from unidentified causes.

##### Buildings in consequences class CC2a:

In addition to the operating principles concerning consequences class CC1, horizontal ties shall be used in class CC2a buildings pursuant to clause 1.1 or horizontal structures shall be anchored to walls pursuant to clause 1.2.

##### Buildings in consequences class CC2b:

In addition to the operating principles concerning consequences class CC1, horizontal structures shall use horizontal ties pursuant to clause 1.1, vertical ties shall be used in all load



bearing columns and walls pursuant to clause 2, and vertical structures shall be bound to horizontal structures pursuant to clause 1.2.

Buildings in consequences class CC3a:

In addition to the operating principles concerning consequences class CC1, horizontal structures shall use horizontal ties pursuant to clause 1.1, vertical ties shall be used in all load bearing columns and walls pursuant to clause 2, and vertical structures shall be bound to horizontal structures pursuant to clause 1.2.

Buildings in consequences class CC3b:

In addition to the operating principles concerning consequences class CC1, a systematic risk assessment of the building should be undertaken in order to account for both foreseeable and unforeseeable hazards. Regardless of the results of the risk assessment, the building shall meet the requirements of consequences class CC3a.

Those parts of the building where the notional removal of a column or a load-bearing wall section pursuant to the definition in clause 3 would cause a horizontal structure that contains horizontal ties to act as an overhang that is the height of the horizontal structure shall also be inspected. If such a notional removal of a structural member results in damage that exceeds the acceptable limit, the structure marked for notional removal shall be considered a key structural member in the risk assessment.

1. Horizontal ties

1.1 Peripheral and internal ties

Horizontal peripheral and internal ties shall be provided around the perimeter of each floor and roof level and internally in two right angle directions. The ties shall be continuous and be arranged as closely as practicable to the edges of floors and lines of columns and walls. At least 30% of the ties shall be located in the immediate vicinity of the grid lines of the columns and the walls.

The ties shall have such deformation capacity that they can act as a replacement load transfer structure or as part of a replacement load transfer structure.

Horizontal ties may comprise timber sections, steel or aluminium sections, reinforcement in concrete structures, or steel mesh reinforcement and prefabricated reinforcing products made of sheet metal for composite slabs (if directly connected to the steel beams with shear connectors). The ties may consist of a combination of the above types. Each continuous tie, including its end connections, should be capable of sustaining a design tensile force for the accidental limit state, equal to the following values:

Consequences classes CC2a and CC2b

The tie forces  $T$  are based on the characteristic value of the permanent actions  $g_k$  for the horizontal structure.

Peripheral and internal ties:

When the characteristic value of the permanent actions for the horizontal structure is  $g_k \geq 3.0 \text{ kN/m}^2$ :

$$T_i = s \cdot 20 \text{ kN} / \text{m} \quad (1)$$

The minimum value for the tie force  $T$  is 70 kN for peripheral ties. If the internal ties must be centred on the supporting line, the minimum value of the tie force, 70 kN, will also be applied to internal ties (e.g. internal ties at the element end seams).

When the characteristic value of the permanent actions for the horizontal structure is  $g_k \leq 2.0 \text{ kN/m}^2$ :

$$T_i = s \cdot 3 \text{ kN} / \text{m} \quad (2)$$

The minimum value for the tie force  $T$  is 10 kN for peripheral ties. If the internal ties must be centred on the supporting line, the minimum value of the tie force, 10 kN, will also be applied to internal ties (e.g. internal ties at the element end seams).

where:

$s$  is, for internal ties, the distance between ties from centre to centre, and for peripheral ties, the distance between the peripheral tie and the closest internal tie divided by two plus the distance to the edge of the building (see Fig. 3).

When the characteristic value  $g_k$  of the permanent actions for the horizontal structure is between 2.0 and 3.0  $\text{kN/m}^2$ , the values for the tie forces can be obtained by interpolation.

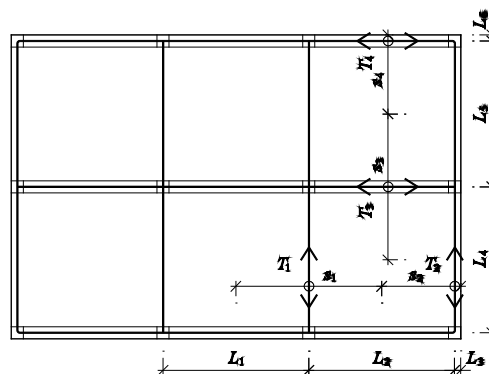

Tie forces:

$$T_1: s_1 = (L_1 + L_2) / 2 \quad T_2: s_2 = L_3 + L_2 / 2 \quad T_3: s_3 = (L_4 + L_5) / 2 \quad T_4: s_4 = L_6 + L_5 / 2$$

**Figure 3.** Determination of the distance  $s$  when calculating horizontal tie forces

### Consequences classes CC3a and CC3b

The tie forces  $T$  are based on the characteristic value of the permanent actions  $g_k$  for the horizontal structure. In consequences classes CC3a and CC3b, the characteristic value for the permanent actions  $g_k$  is usually greater than  $3.0 \text{ kN/m}^2$ . If, however, the characteristic value of the permanent actions  $g_k$  is smaller than this value, the tie forces may be defined on a project basis.

Peripheral and internal ties:

When the characteristic value of the permanent actions for the horizontal structure is  $g_k \geq 3.0 \text{ kN/m}^2$ :

$$T_i = \frac{F_t \cdot 0,8 \cdot (g_k + \sum \psi_i q_k)}{6 \frac{\text{kN}}{\text{m}^2}} \frac{z}{5m} \cdot s \text{ but at least } T_i = F_t \cdot s \quad (3)$$

where:

$F_t$  is  $48 \text{ kN/m}$  or  $(16 + 2.1 n_s) \text{ kN/m}$ , whichever is smaller

$g_k$  is the characteristic value of the permanent actions for the horizontal structure. If several variable actions act on the horizontal structure, the variable actions acting across the calculation width  $s$  are added together by applying the combination rules for an accidental limit state.

$\psi_i$  is the combination factor for a variable action during an accidental limit state ( $\psi_1$  or  $\psi_2$  depending on the action)

$q_k$  is the characteristic value of the variable action for the horizontal structure

$s$  is, for internal ties, the distance between ties from centre to centre, and for peripheral ties, the distance between the peripheral tie and the closest internal tie divided by two plus the distance to the edge of the building (see Fig. 3)

$n_s$  is the number of storeys in the entire building

$z$  is the distance between column or wall centre lines in the direction of the tie, or if the tie is in the direction of a load-bearing wall, it is the nominal length of the section marked for notional removal defined in clause 4 divided by two ( $z$  is the assumed safe value of half of the span when utilising catenary action, see Fig. 4).

a)

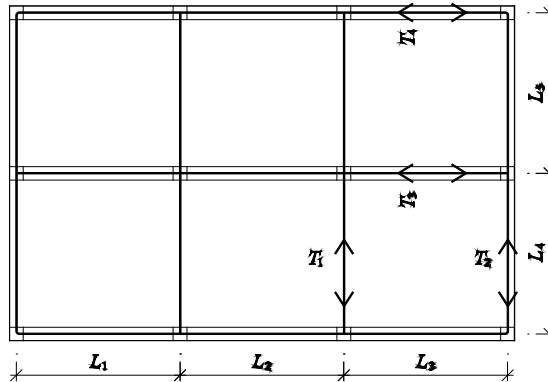

Tie forces in a framed structure:  $T_1$  and  $T_2$ :  $z = \max(L_4, L_5)$   $T_3$  and  $T_4$ :  $z = \max(L_1, L_2, L_3)$

b)

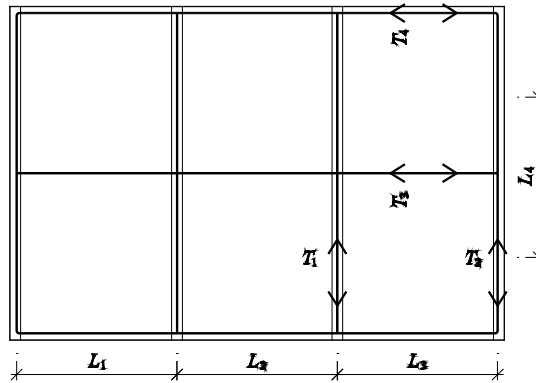

Tie forces in a load-bearing wall construction:

$T_1$  and  $T_2$ :  $z = L_4/2$ , where  $L_4$  the nominal length of the load-bearing wall section (see clause 3):

$T_3$  and  $T_4$ :  $z = \max(L_1, L_2, L_3)$

**Figure 4.** Determination of the distance  $z$  when calculating horizontal tie forces

Structural members used for sustaining actions other than accidental actions may be utilised as the above ties.

## 1.2 Horizontal ties to columns and walls

Edge columns and walls shall be tied to every floor and roof. The tie forces are based on the characteristic value of the permanent actions  $g_k$  for the horizontal structure. The ties should be capable of sustaining the following forces in accidental limit state:

Consequences classes CC2a and CC2b

$$F_{tie} = 20 \frac{kN}{m} \cdot s \quad \text{when the characteristic value of the permanent actions for the horizontal structure is } g_k \geq 3.0 \text{ kN/m}^2 \quad (4)$$

$$F_{tie} = 3 \frac{kN}{m} \cdot s \quad \text{when the characteristic value of the permanent actions for the horizontal structure is } g_k \leq 2.0 \text{ kN/m}^2 \quad (5)$$

but no more than  $F_{tie} = 150kN$

where:

$s$  is the calculation width of the tie force, which is measured from centre to centre of the clear distance of vertical structures or to the edge of the building when the vertical structures are located in the outer corner (see Fig. 5).

When the characteristic value  $g_k$  of the permanent actions for the horizontal structure is between 2.0 and 3.0 kN/m<sup>2</sup>, the values for the tie forces can be obtained by interpolation.

#### Consequences classes CC3a and CC3b

The tie forces are based on the characteristic value of the permanent actions  $g_k$  for the horizontal structure. If the characteristic value of the permanent actions of the horizontal structure is  $g_k \geq 3.0 \text{ kN/m}^2$ , the below equation (6) may be applied. If the characteristic value of the permanent actions  $g_k$  is smaller than this value, the tie forces may be defined on a project basis.

$$F_{tie} = F_t \cdot \frac{h}{2,5m} \cdot s, \text{ but no more than } F_{tie} = 2 \cdot F_t \cdot s \quad (6)$$

where:

$F_t$  is 48 kN/m or  $(16 + 2.1 n_s)$  kN/m, whichever is smaller

$h$  is the storey height

$s$  is the calculation width of the tie force, which is measured from centre to centre of the clear distance of vertical structures or to the edge of the building when the vertical structures are located in the outer corner (see Fig. 5).

$n_s$  is the number of storeys in the entire building

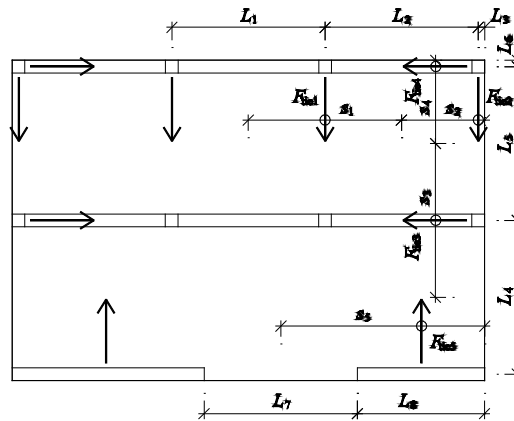

Tie forces:

$$F_{\text{tie1}}: s_1=(L_1+L_2)/2 \quad F_{\text{tie2}}: s_2=L_3+L_2/2 \quad F_{\text{tie3}}: s_3=(L_4+L_5)/2$$

$$F_{\text{tie4}}: s_4=L_6+L_5/2 \quad F_{\text{tie5}}: s_5=L_8+L_7/2$$

**Figure 5.** Determination of the calculation width  $s$  for the tie force when calculating the tie force of the walls and columns (the wall ties may be placed along the entire length of the wall)

Corner columns are tied in both directions.

Peripheral or internal ties may be used for tying columns if the reinforcement is anchored to the columns.

## 2. Vertical ties

Each column and wall shall be supplied with continuous vertical ties from the foundations to the roof level.

The columns and walls carrying vertical actions shall be capable of resisting an accidental design tensile force equal to the largest design vertical permanent and variable load reaction applied to the column from any one storey. The tensile force is anchored to the upper floor.

The vertical ties in a load-bearing wall structure may be placed at the element seams or distributed along the length of the wall; the outermost vertical ties are located at a distance of at most 3 m from the free-standing end of the wall.

## 3. Nominal section of a load-bearing wall

The nominal section of a load-bearing wall is the distance between vertical structural members that act as horizontal support, however at most  $2.25H$ , where  $H$  is the storey height in metres.

Instruction

### **Design of alternative load transfer routes**

Alternative load transfer routes are designed for the design loads of an accidental situation. In the design of an alternative load transfer route, it is thought that a column, a joist supporting a column, a joint between a column and a joist, or a section of a load-bearing wall pursuant to the definition of clause 3 in the instruction concerning tying systems (one at a time on each floor of the building) is removed from the building.

Instruction

### **Definition of key components of building structure**

The vertical structures of the building shall mainly be designed as non-key components of building structure. The procedure for a key component may only be used if an alternative load transfer route cannot be formed. Typically, such places may be columns located at the outer corners of the building, for example. Not all vertical structures in a building can be considered key components of building structure.

A key component of building structure is tied to a horizontal structure in a manner corresponding to the accidental action  $A_d$  in order to allow the horizontal structure to transfer the force to the bracing structures.

When assessing the force transferred through the components, the ultimate strength of the components and their fastenings is taken into account.

## **7. Principles for ensuring the robustness of a hall-type building**

**Ministry of the Environment Decree (10/16)**  
**concerning national choices for accidental actions, when applying standard SFS-EN 1991-1-7**  
*Section 7 Principles for ensuring the robustness of a hall-type building*

Sufficient robustness of a hall-type building, in accordance with clause 3.3(2), Note 3 of the standard, shall be ensured so that a localised failure does not exceed the limits given in section 4. Localised failure is limited by means of structural measures.

For buildings in consequences class CC3b, a systematic risk assessment of the building should be undertaken, thereby taking into account both foreseeable and unforeseeable hazards. If accidental actions can be specified by risk assessment, they shall be taken into consideration. Accidental actions include linear loads, concentrated loads, weight loads, deformations or deformation forces.

## Instruction

Localised damage can be limited by means of one of the following actions:

- designing alternative load transfer routes
- increasing the static indeterminacy of the structure and ensuring the toughness of the structural joints
- by using a sufficient number of bracing structures on the roofs and walls
- by ensuring that the stability of the main supports is retained even after localised damage
- by designing secondary structures in a manner that prevents them from expanding the collapsed area



## 8. Impact on supporting substructures

**Ministry of the Environment Decree (10/16)**  
**concerning national choices for accidental actions, when applying standard SFS-EN 1991-1-7**  
*Section 8 Impact on supporting substructures*

The values given in Table 1 for actions due to impact shall be complied with, in accordance with clause 4.3.1(1) of the standard. The values given in the table do not apply to areas that are not accessible to vehicles.

The design forces for building structures given in Table 1 for the category of traffic may be multiplied by a reduction factor taken from Figure 1 as a function of distance  $d$  and the maximum permitted speed of the vehicle  $v_0$ , provided that the maximum speed limit is less than 80 km/h. Distance  $d$  is measured from the structural member to the centreline of the nearest trafficked lane. The design forces shall meet, at the least, the requirements for the category of traffic *courtyards and parking garages* in Table 1. The values for the reduction factors for speeds between 40 km/h and 80 km/h can be obtained by linear interpolation. The reduction factors given in Figure 1 can be applied when the downward slope between the centreline of the nearest trafficked lane and the point of impact, measured perpendicularly to the lane, is no more than 1:5. The effect of slopes steeper than this and the effect of upward slopes, as well as the effect of rails and other measures to avoid impact, shall be specified for the individual project, in accordance with clause 4.3.1(1), Note 2 of the standard.

**Table 1.** Indicative equivalent static design forces due to vehicular impact on supporting structures over or adjacent to roadways.

Category of traffic	Force $F_{dx}^a$ [kN]	Force $F_{dy}^a$ [kN]
Motorways, country roads and main roads with a maximum speed limit of $v \geq 80$ km/h	1100	550
Streets and main roads with a maximum speed limit of $50 \text{ km/h} \leq v < 80 \text{ km/h}$	825	410
Streets and main roads with a maximum speed limit of $v < 50 \text{ km/h}$	550	275
Courtyards and parking garages that are: accessible to passenger cars and delivery vans <sup>b</sup> accessible <sup>b</sup> to lorries <sup>c</sup>	25	25
	75	75
<sup>a</sup> $x$ = direction of normal travel, $y$ = perpendicular to the direction of normal travel. <sup>b</sup> If the horizontal distance from the structure to the edge of the courtyard area planned for vehicular traffic is at least 2.0 m, it is not necessary to design the structure for vehicular impact. <sup>c</sup> The term 'lorries' refers to vehicles with a maximum gross weight of more than 3.5 tonnes.		

When distance  $d$  is so great that the reduction factor obtained from Figure 1 is zero, it is not necessary to design for actions due to vehicular impact.

It is not necessary to consider actions due to vehicular impact on structures in consequences class CC1, in accordance with clause 4.3.1(1), Note 3 of the standard.

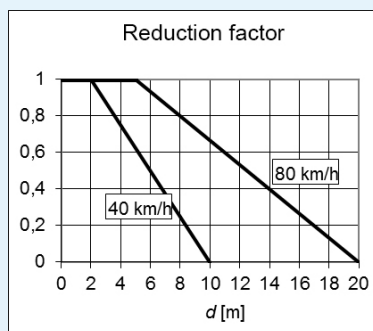

**Figure 1.** Reduction factor for design forces for building structures in the category of traffic *Roads in urban area*.

A reduction factor  $r_F$  is not applied to the category of traffic *Courtyards and parking garages*, in accordance with clause 4.3.2(1), Note 3 of the standard.

In determining the value of force  $F$  for accidental actions due to impact from forklift trucks, in accordance with clause 4.4(1) of the standard,  $W$  is the sum of the net weight and hoisting load of a loaded truck, unless a more accurate method is applied. Force  $F$  is applied at a height of 0.75 m above floor level.

**Table 2.** Indicative equivalent static design forces for building structures due to impact on superstructures.

Category of traffic	Equivalent static design force $F_{dx}$ <sup>a</sup> [kN]
Motorways, country roads and main roads	500
Country roads in rural area	375
Roads in urban area	250
Courtyards and parking garages	75
<sup>a</sup> x = direction of normal travel.	

The horizontal static equivalent design forces parallel or transverse to the railway due to impact caused by the derailling of rail traffic running under or adjacent to a Class A structure, in accordance with clause 4.5.1.4(5) of the standard, can be reduced so that  $F_{dx} = F_{dy} = 0$ , when  $d > 20$  m. In other cases, the values are determined for the individual project. When distance  $d$  is greater than 5 m, no requirements are specified for Class B structures, in accordance with clause 4.5.1.5(1) of the standard. In other cases, the values are determined for the individual project.

## 9. Annex A: Design for consequences of localised failure in buildings from an unspecified cause

### Ministry of the Environment Decree (10/16)

#### concerning national choices for accidental actions, when applying standard SFS-EN 1991-1-7

#### Section 9 Annex A: Design for consequences of localised failure in buildings from an unspecified cause

Annex A is not applied.

# National Annex to standard SFS-EN 1991-3: Actions on structures.

## Part 3: Actions induced by cranes and machinery

### 1. Scope

**Ministry of the Environment Decree (11/16)**  
**concerning national choices for actions induced by cranes and machinery, when applying standard SFS-EN 1991-3**  
*Section 1 Scope*

This Decree is applied in the selection of actions induced by cranes and machinery and is used in conjunction with the latest version of standard SFS-EN 1991-3.

#### Instruction

As regards standard SFS-EN 1991-3, the recommended values set forth in standard SFS-EN 1991-3 and all the annexes to standard SFS-EN 1991-3 are followed unless otherwise stated in this National Annex.

National choice is permitted in the following clauses of standard SFS-EN 1991-3:

- 2.1(2), Section 2
- 2.5.2.1(2)
- 2.5.3(2)
- 2.7.3(3), Note 2
- A.2.2(1), Section 3
- A.2.2(2), Section 3
- A.2.3(1), .

A national choice has been made in the clauses marked •.

### 2. Actions induced by hoists and cranes on runway beams

**Ministry of the Environment Decree (11/16)**  
**concerning national choices for actions induced by cranes and machinery, when applying standard SFS-EN 1991-3**  
*Section 2 Actions induced by hoists and cranes on runway beams*

Where the crane supplier is known at the time of design of crane runway beams, in accordance with clause 2.1(2) of the standard, the wheel loads specified by the crane manufacturer shall be primarily used for actions induced on runways. The actions should be given as static values without partial safety factors. The actions shall be classified as permanent actions and variable and accidental actions. The dynamic factors for different actions shall be reported. For designing the building frame, the simultaneous actions on different crane runways shall be reported. For the purpose of fatigue analysis, the rate of planned load accumulation of all cranes running on crane runways shall be reported.

Instruction

### Vertical actions

#### 2.5.2.1(2)

The recommended value is adopted for the eccentricity of the wheel load presented in clause 2.5.2.1(2) of the standard. For fatigue analysis, the lower value for eccentricity can be used in particular cases, when the eccentricity tolerance of the rail relative to web and any possible inaccuracies of the crane wheels are taken into account in its determination. For the value of the eccentricity of the rail relative to web,  $\Delta = 5$  mm is adopted when the thickness of the web  $t_w \leq 10$  mm and  $\Delta = 0.5 t_w$ , when  $t_w > 10$  mm. The inaccuracies of the crane wheels should be determined together with the crane supplier. If the inaccuracies are not determined, the recommended value  $e = 0.25 b_r$  is adopted.

## 3. Annex A: Basis of design — supplementary clauses to EN 1990 for runway beams loaded by cranes

**Ministry of the Environment Decree (11/16)**  
**concerning national choices for actions induced by cranes and machinery, when applying standard SFS-EN 1991-3**  
*Section 3 Annex A: Basis of design — supplementary clauses to EN 1990 for runway beams loaded by cranes*

The partial safety factors given in Table 1 shall be applied to crane actions in accordance with clause A.2.2(1) of the standard. The values given in the table shall also be applied when designing load-bearing structures carrying crane runway beams.

Table 1. Design values of crane actions (STR/GEO)

Persistent and transient design situations		Eq.6.10a	Eq.6.10b
Permanent actions	Unfavourable	$1.35K_{FI}G_{kj,sup}$	$1.15K_{FI}G_{kj,sup}$
	Favourable	$1.0G_{kj,inf}$	$1.0G_{kj,inf}$
Crane action is the leading variable action			$1.35K_{FI}Q_{k,1}$
Crane action is an accompanying variable action			$1.35K_{FI}\psi_{0,i}Q_{k,i}$

The values  $\gamma_{Gsup} = 1.1$  and  $\gamma_{Ginf} = 0.9$ , set out in the Ministry of the Environment Decree concerning national choices for standard SFS-EN 1990, shall be applied to the partial safety factors in accordance with clause A.2.2(2) of the standard.

Instruction

#### A.2.2(1)

As regards other actions, the Decree of the Ministry of the Environment concerning the national choices for standard SFS-EN 1990 shall be followed.

#### A.2.3(1)

The recommended values presented in clause A.2.3(1) are adopted for the combination factors of crane actions. The values are also used when designing crane supporting structures. For structural fire design, only the permanent crane actions are taken into account. It is not necessary to dimension crane runways for fire actions, unless otherwise stated in project specifications. In the project specification, special attention shall be paid to the rescue routes and attack routes for the fire brigade, for which the crane runway may have to be locally dimensioned for fire actions.

# National Annex to standard SFS-EN 1991-4: Actions on structures.

## Part 4: Actions on silos and tanks

### 1. Scope

**Ministry of the Environment Decree (12/16)**  
**concerning national choices for loads on silos and tanks, when applying standard SFS-EN 1991-4**  
*Section 1 Scope*

This Decree is applied in the selection of loads on silos and tanks and is used in conjunction with the latest version of standard SFS-EN 1991-4.

#### Instruction

As regards standard SFS-EN 1991-4, the recommended values set forth in standard SFS-EN 1991-4 and all the annexes to standard SFS-EN 1991-4 are followed unless otherwise stated in this National Annex.

National choice is permitted in the following clauses of standard SFS-EN 1991-4:

- 2.5(5), Note 1
- 3.6(2)
- 5.2.4.3.1(3)
- 5.4.1(3), Note 1
- 5.4.1(4)
- A.4(3)
- B.2.14(1).

A national choice has been made in the clauses marked •.

## 2. Annex A to the standard: Basis of design – supplementary paragraphs to EN 1990 for silos and tanks

**Ministry of the Environment Decree (12/16)**  
**concerning national choices for loads on silos and tanks, when applying standard SFS-EN 1991-4**  
*Section 2 Annex A to the standard: Basis of design – supplementary paragraphs to EN 1990 for silos and tanks*

Annex A provides supplementary guidance applicable to actions on silos concerning partial factors and on combinations of actions on silos:

- 1) The combination factors given in Annex A, Tables A.1, A.2, A.3, A.4 and A.5 are not applicable. The combination factors shall be selected in accordance with Annex A and Annex B and shall comply with the Ministry of the Environment Decree concerning national choices for the basis of structural design, when applying standard SFS-EN 1990;
- 2) for actions on silos, in accordance with clause A.2.1(1) of the standard, the value of the partial safety factor is  $\gamma_F=1.5$ . With regard to other actions in the design of silos, the Ministry of the Environment Decree concerning national choices for the basis of structural design, when applying standard SFS-EN 1990, shall be complied with; and
- 3) in design situations and action combinations for Action Assessment Classes 2 and 3 for actions on silos, in accordance with clause A.4 of the standard, the value of the combination factor  $\psi_0$  shall be 1.0, the value of the frequent combination factor  $\psi_1$  shall be 0.9, and the value of the quasi-permanent combination factor  $\psi_2$  shall be 0.8.

## 3. Annex B to the standard: Actions, partial factors and combinations of actions on tanks

**Ministry of the Environment Decree (12/16)**  
**concerning national choices for loads on silos and tanks, when applying standard SFS-EN 1991-4**  
*Section 3 Annex B to the standard: Actions, partial factors and combinations of actions on tanks*

Annex B provides supplementary guidance applicable to actions on tanks concerning partial factors and on combinations of actions on tanks:

- 1) the party engaging the building project shall specify the accidental actions to be considered, in accordance with clause B.2.14 of the standard;
- 2) during operation, the value of the partial factor for the liquid induced loads and the actions on the tank due to weight  $\gamma_F$  is 1.35, in accordance with clause B.3(2) of the standard. The values in Annex A, clause A.2.1(2), are not applied; or
- 3) for the liquid induced loads and the actions on the tank due to weight, the value of the combination factor  $\psi_0$  shall be 1.0, the value of the frequent combination factor  $\psi_1$  shall be 0.9, and the value of the quasi-permanent combination factor  $\psi_2$  shall be 0.8.